

VIMTM

RUBBER

CONVEYOR TOOLS



YOUR ORIGINAL CHOICE

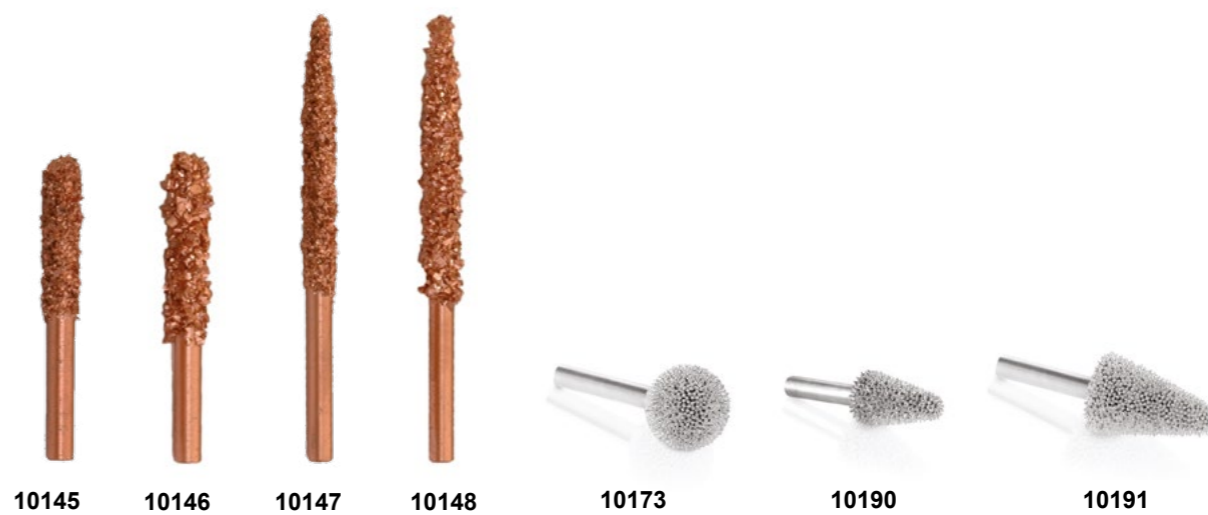

Code	MFG	Shaft	Size	Grit
10145	22-15	Ø 6	65	36
10146	22-16	Ø 6	65	16
10147	22-17	Ø 6	102	36
10148	22-18	Ø 6	102	16
10173	603	Ø 6	Ø 22	330/24
10190	611	Ø 6	Ø 16x25	330/24
10191	613	Ø 6	Ø 22x32	330/24



Code	Adapters
10519	3/8" UNF x 16 mm
10524	Ø 14 x 15 mm
10530	Ø 3 mm
10532	Ø 6 mm
10534	Ø 10 mm
10550	Ø 6 - 3/8" UNF x 10 mm
10551	Ø 6 - 3/8" UNF x 25 mm



Code	Model
12507	Coltello a lama dritta 4" - 100mm / Rubber Knife - straight blade 4" - 100 mm
12508	Coltello a lama dritta 6" - 150mm / Rubber Knife - straight blade 6" - 150 mm
12509	Coltello a lama dritta 8" - 220mm / Rubber Knife - straight blade 8" - 220 mm
12510	Scimitarra 8" - 220 mm / Scimitar 8" - 220 mm
10994	Coltello quarto di luna/Quarter moon shaped knife
10995	Coltello flat moon / Flat moon knife
11244	Trincetto industriale / Industrial curved v-trim knife
12515	Pietra affilalame / Knife sharpening stone
10985	Taglierino L= 160 mm / Cutter L= 160 mm
10986	Lama di ricambio per taglierino 10985 -110 x 80 x 0.6 box 10 pz / Spare blade for cutter 10985 110 x 80 x 0.6 box 10 pcs
10987	Taglierino L= 180 mm rubber touch / Cutter L=180 mm rubber touch
10988	Lama di ricambio per taglierino 10987- 140 x 25 x 0.7 box 10 pz / Spare blade for cutter 10987- 140 x 25 x 0.7 box 10 pcs
11032	Coltello ad uncino / Hook knife
11008	Coltello ad uncino Dexter 50 mm - 2" / Dexter knife 50 mm - 2"
11009	Coltello ad uncino (modello Dexter) 50mm - 2" - manico in plastica Hook knife (Dexter model) 50mm - 2" - plastic handle



Code	Model
10996	Punteruolo ad uncino / Hooked awl
10997	Coltello taglia tele / Rotary cutting knife
10998	Lame di ricambio per coltello 10997 / Spare blade for knife 10997
10999	Coltello ad angolo con manico in legno / Offset knife for rubber - wood handle
11000	Coltello ad angolo VMR con manico in plastica / VMR offset knife for rubber - plastic handle
11001	Coltello Don Paolo con manico in legno / Don Paolo knife with wooden handle
11002	Lama ricambio per coltello Don Paolo / Spare blade for Don Paolo knife
11003	Spazzola carda a mano VMR / VMR curved hand brush
11005	Spazzola carda a mano / Curved hand brush
11006	Ricambio spazzola carda a mano / Curved hand brush spare pads
11013	Taglia tele non regolabile / Not adjustable cutter
11222	Coltello lama rotante Ø 45 mm / Rotary cutting knife Ø 45 mm
11223	Lama di ricambio per coltello 11222 / Spare blade for knife 10997



11059



11381



11382



11036



11322



12536



12541



12559



12543



12547

Code	Model
11029	Tenaglia 220 mm / Pliers 220 mm
11030	Tenaglia 250 mm / Pliers 250 mm
11031	Tenaglia 280 mm / Pliers 280 mm
11036	Pinza speciale L = 200 mm / Special clamp L = 200 mm
11322	Pinza speciale curva L = 200 mm / Special curved plier L = 200 mm
11059	Pinza Knipex L = 250mm / Knipex Pincer L = 250 mm
11381	Tenaglia speciale Knipex L = 300 mm / Special Knipex Pincer L = 300 mm
11382	Pinza autobloccante - ganasce piatte 200 mm / Clamp lock-grip pliers flat clamp 200 mm
12536	Portalamo piatto / Flat bladeholder
12543	Lama a 9 denti / Blade 9 teeth
12541	Portalamo gigante e regolabile / Giant and adjustable bladeholder
12547	Lama gigante 14 denti curvi / Giant blade 14 curved teeth
12559	Cesoia universale Bosch / Bosch universal cutter



11029



11030



11031



11022



11020



11026



11024

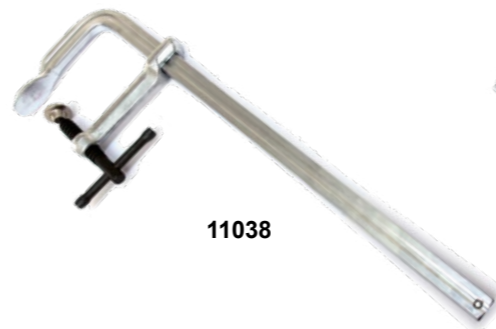

11038



11037



10983



11017

11018

11019



Code	Model	Size	Weight	Max Pull
11017	4 barre e 4 morsetti per nastri 24" / 4 heavy duty belt clamps and 4 yokes 24"	L= 609 mm	20,58 kg	3t
11018	4 barre e 4 morsetti per nastri 36" / 4 heavy duty belt clamps and 4 yokes 36"	L= 915 mm	33,30 kg	3t
11019	4 barre e 4 morsetti per nastri 48" / 4 heavy duty belt clamps and 4 yokes 48"	L= 1.220 mm	40 kg	3t
11037	Strettoio a vite / Clamp with screw	300 x 140 mm	1,80 kg	-
11038	Strettoio a vite / Clamp with screw	500 x 120 mm	2,10 kg	-
11020	Fibbia per nastri L= 180 mm / Belt cover puller L=180mm	L= 180 mm	1,45 kg	600 kg
11022	Fibbia per nastri L= 220 mm / Belt cover puller L= 220 mm	L= 220 mm	3,18 kg	1250 kg
11024	Pinza per nastri sp 25mm / Grip clamp thk 25 mm	thk 25 mm	3,15 kg	8 kn
11026	Pinza per nastri sp 55 mm / Grip clamp thk 55 mm	thk 55 mm	6,40 kg	30 kn
10983	Pinza strappa nastro / Pulling clamp	-	0,78 kg	-

KIT RIPARAZIONE NASTRI 10979

SPLICING TOOL KIT 10979



1	Borsa porta attrezzi / Tool bag
1	Gessi bianchi / White Crayons Ø 13 x 115 mm 12 Pcs
3	Pennarello argento per marcatura gomma - Silver rubber marking pen
1	Tracciatore blu / Chalk dust blue 30 mt
1	Occhiali in policarbonato / Safety goggles
1	Guanti da lavoro / Work gloves
1	Inseri auricolari con archetto / Earplugs
1	Metro in acciaio 5m / 5 mt steel tape
1	Pinza strappa nastro / Pulling Clamp
1	Fibbia per nastri / Belt Cover Puller L= 180 mm
1	Strettoio a vite / Clamp with Screw 300 x 140 mm
1	Pennello / Brush Ø 55
1	Spazzola da banco / Hand brush 350 x 35 mm
1	Martello in gomma / Rubber hammer Ø 50 mm - gr 500
1	Mola/Carbide wheel TFW415 100x40 grit 36
1	Gambo esagonale / Hexagonal adapter 3/8" UNF x 16
1	Spazzola circolare concava / Grooved wire brush Ø 100 x 27
1	Disco piatto / Flat Disc 180 x 2 AH 22 grit 18
1	Spazzola circolare Clepsydra / Clepsydra steel wire brush ø 60 x 30 mm
1	Rullino zigrinato / Knurled Stitcher 50x4 mm
1	Rullino zigrinato / Knurled Stitcher 50x6 mm
1	Rullino a punte intercambiabili / Pin stitcher 52x27 mm
1	Rullino liscio / Smooth roller 40x18 mm
1	Punte cilindrica per foratura nastri / Spare belt punch Ø 6
1	Punte cilindrica per foratura nastri / Spare belt punch Ø 8
1	Tenaglia / Plier 220 mm
1	Pinza speciale /Special clamp L = 200 mm
1	Pietra affilalame / Knife sharpening stone
1	Punteruolo conico / Conical awl Ø 8 x 95 mm
1	Coltello ad uncino Dexter / Dexter hook knife 50mm / 2"
1	Coltello a lama dritta / Rubber knife 6"- 150 mm
1	Punteruolo ad uncino / Ply lifter
1	Coltello ad angolo con manico in legno / Offset knife wooden handle
1	Coltello Don Paolo / Don Paolo Knife
1	Taglierino / Cutter L= 160 mm
1	Lama di ricambio per taglierino /Spare blade for cutter 10985 110x18x0.6
1	Coltello taglia tele / Rotary cutting knife
1	Forbice per gomma / Shears for rubber 12" 305mm
1	Spazzola carda a mano / Scratcher brush

*Kit personalizzabile/ The kit can be customized



10961



10963



11218



11217



10580 RPM 2.800



10568 RPM 22.000

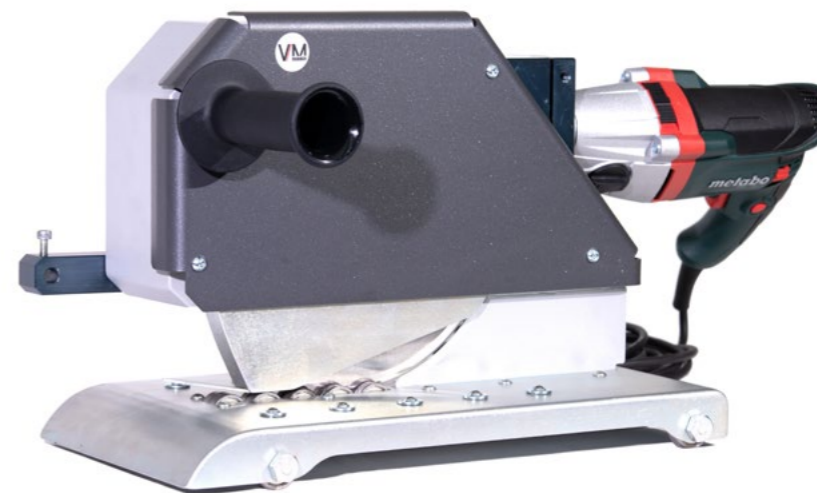

11055

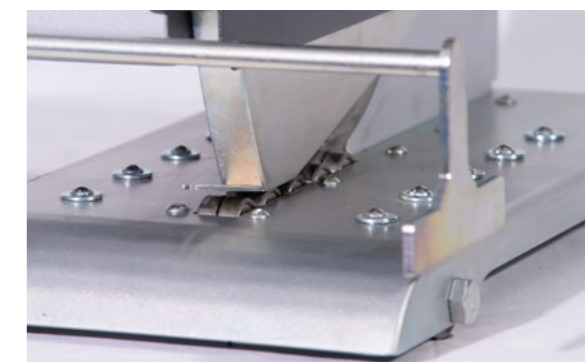

Taglianastri elettrica VMR / VMR Electrical Belt Cutter

Potenza Trapano / Drill Power	780 W - 32 Nm
Potenza Elettrica / Electric Power	230 V
Spessore Massimo / Max THK	50 mm
Peso / Weight	18 kg

Code	Model	RPM	Power
10963	Smerigliatrice angolare Bosch GWS 22-180 J Ø150 Angle Bosch grinder GWS 22-180 J Ø150	8.500	230V 2200W 50Hz
10961	Smerigliatrice assiale Bosch (pinza fino a 8mm) Axial Bosch grinder (collets up to 8mm)	2.500-8.000	230V 750W 50Hz
11217	Levigatrice a nastro Makita / Makita belt sander 30x533 mm	200-1.000	230V 550W
11218	Nastro abrasivo / Abrasive belt 30x533 mm Grit 40	-	-
11219	Nastro abrasivo / Abrasive belt 30x533 mm Grit 60	-	-
10580	Smerigliatrice CP 873 / Air Buffer CP 873	2.800	-
10568	Smerigliatrice CP 872 / Air Buffer CP 872	22.000	-

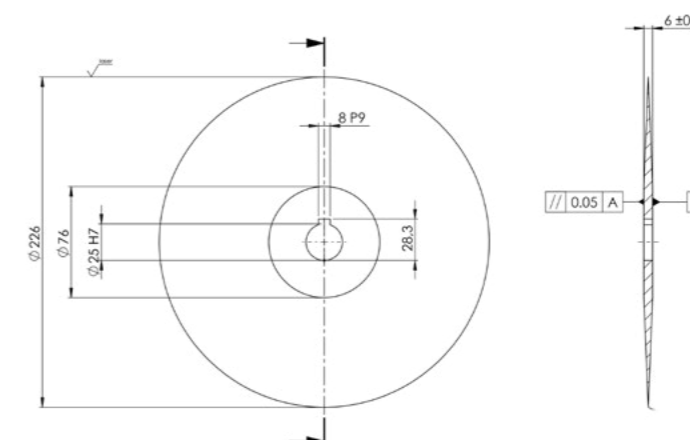

11057
Lama di ricambio/ Spare blade



11832

Estrusore Elettrico VMR / VMR Electrical Extruder Gun

Potenza Trapano / Drill Power	780 W
Potenza Elettrica / Electric Power	230 V
Temperatura Max / Max Temperature	120°
Peso / Weight	5 Kg
Produzione di gomma / Rubber Production	18 Kg/h



11380

Estrusore Metabo VMR A+B 1800W / A+B VMR Metabo Extruder Gun 1800W

Potenza Trapano / Drill Power	1800 W
Potenza Elettrica / Electric Power	230 V
Peso / Weight	11 Kg
Produzione gomma / Rubber production	28 Kg/h



10952

11754

10953

Code	Model
11754	Gomma per la pulizia dell'estrusore 3x18x300mm / Cleaning rubber for extruders 3x18x300 mm - 1 box/5 rolls
10952	Trafilatore in gomma autovulcanizzante A+B 3x 20 x 5.500 mm 2+2 Kg / Self-curing A+B rubber 3x20 x 5.500 mm 2+2 Kg
10953	Kit soluzione mastice per A+B (1Kg+1Kg) / Glue solution kit for A+B compound (1Kg+1Kg)



11323

Estrusore Elettrico VMR A+B / A+B VMR Electrical Extruder Gun

Potenza Trapano / Drill Power	780 W
Potenza Elettrica / Electric Power	230 V
Peso / Weight	5 Kg
Produzione gomma / Rubber production	18 Kg/h



Code	Model
10989	Pennello Ø 36 (595 0186) / Brush Ø 36
11462	Pennello ø 55 / Brush Ø 55
11459	Spazzola (595 4553) / Brush (595 4553)
11469	Spazzola da banco 350 x 35 mm / Hand brush 350 x 35 mm
11651	Gessi bianchi Ø 13x115 box 12Pcs / White crayons Ø 13x115 box 12Pcs
11652	Gessi gialli Ø 13x115 box 12Pcs / Yellow crayons Ø 13x115 box 12Pcs
11027	Tracciatore 30 m / Chalk dust 30 m
11028	Ricarica tracciatore 100 gr / Chalk dust refill (blue) 100 gr
11657	Pennarello per marcatura gomma - argento (595 0045)/Rubber marking pen - silver (595 0045)
12557	Forbice per gomma / Shears for rubber 12" 305 mm
12530	Forbice per gomma / Shears for rubber 8" 220 mm
12531	Forbice per gomma / Shears for rubber 10" 290 mm
12629	Silicone liquido / Concentrated liquid silicone 25 kg



Code	Model
11200	Punta di ricambio cilindrica per foratura nastri Ø 6 / Spare belt punch Ø 6
11201	Punta di ricambio cilindrica per foratura nastri Ø 8 / Spare belt punch Ø 8
11202	Punta di ricambio cilindrica per foratura nastri Ø 10 / Spare belt punch Ø 10
11203	Punta di ricambio cilindrica per foratura nastri Ø 12 / Spare belt punch Ø 12
12555	Scalda coltelli 230 V - coltello 10" - 290mm / Knife heater 230 V - Knife size 10" 290mm max. temperature 240°
11884	Trapano Metabo 230V 780W mandrino 1.5 - 13 mm / Metabo drill 230V 780W chuck 1.5 - 13 mm

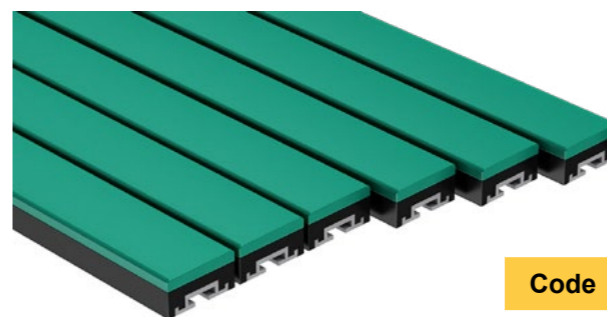

Code	Bar Length	Bar Width	Bar Height	Bolt. dimensions
11097-1	1200 mm	100 mm	50 mm	16x40 mm
11097	1200 mm	100 mm	75 mm	16x40 mm
11098	1500 mm	100 mm	75 mm	16x40 mm



10977

Potenza Motore / Power	2.2 KW
Tensione / Voltage	380 V
Velocità sollevamento / Lifting speed	21 m / min.
Lunghezza fune / Rope length	25 m (max 40 m)
Diametro fune / Wire rope diameter	7 mm
Portata / Load capacity	500 Kg
Peso / Weight	66 Kg



10976



10975

Code	Model
10975	Argano manuale a fune 800 Kg / Cable winch 800 Kg
10976	Paranco a leva - 1500 Kg, H=1500 mm / Chain winch 1500 Kg - H =1500 mm
10977	Argano elettrico / Electric winch



10991



10990

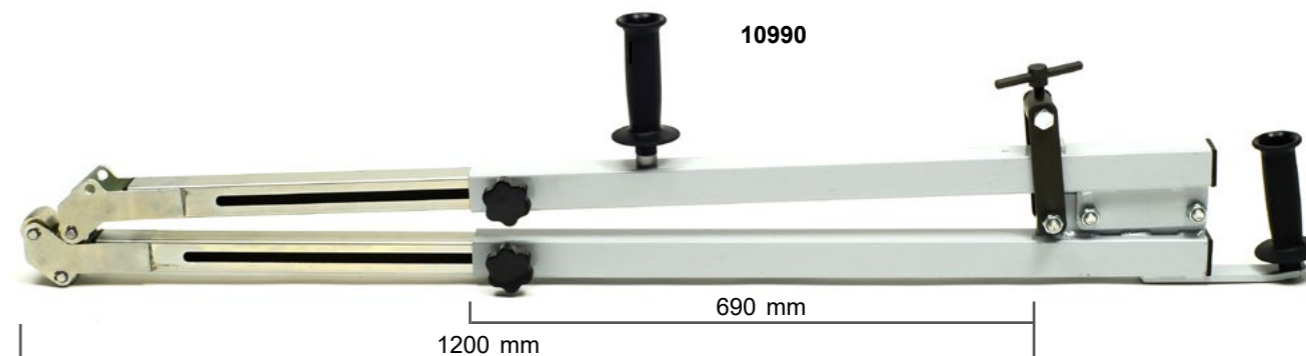

Code	Model
10991	Rullo doppia azione - misura 1 420 mm / Double acting roller - size 1 420 mm
10992	Rullo doppia azione - misura 2 620 mm / Double acting roller - size 2 620 mm
10993	Rullo doppia azione - misura 3 820 mm / Double acting roller - size 3 820 mm
10990	Rullo doppia efficacia telescopico L= 690 mm - 1200 mm / Telescopic double acting roller L= 690 mm - 1200 mm
10990-1	Rullo doppia azione - misura 4 1220 mm / Double acting roller - size 4 1220 mm



10965

Code	Model
10965	Termosoffiatore 2000 W / Hot air gun 2000 W



Code	Model
10984	Riga flessibile L =1000 mm - 39" / Metal layout ruler L =1000 mm - 39"
11014	Squadra in plastica con angolo 800 x 340 mm / Plastic set square 800 x 340 mm
11039	Squadra semplice in metallo 500 x 280 mm / Metal angle set square 500 x 280 mm
11708	Nastro in fibra di vetro 10 m / 10 m fiber glass tape
11715	Metro in acciaio 5 m / 5 m steel tape
11712	Durometro 0-100 shore A / Durometer 0-100 shore A
11713	Durometro digitale 0-100 shore A / Digital durometer 0-100 shore A
11711	Misuratore di spessore corsa 0-30 mm profondità 300 mm / Thickness gauge range 0-30 mm yoke 300 mm
11711-1	Misuratore di spessore corsa 0-30 mm profondità 450 mm / Thickness gauge range 0-30 mm yoke 450 mm



Code	Model
10950	Raschiatore rimuovi gomma 730 W - 230 V / Rubber skiver 730 W 230 V
10951	Lama di ricambio per raschiatore 10950 / Spare blade for rubber skiver 10950
11225	Raschiatore elettrico rimuovi gomma 400 W - 230 V / Rubber skiver 400 W 230 V
10959	Lama per cod. 11225 / Spare blade for code 11225
10960	Lama per cod. 11225 / Spare blade for code 11225
11226	Raschiatore Fein rimuovi gomma 250 W / Fein rubber skiver 250 W
10954	Kit lame e-cut per Fein 11226 / E-cut blades kit for Fein 11226



Cod. 12440
230V - 370W

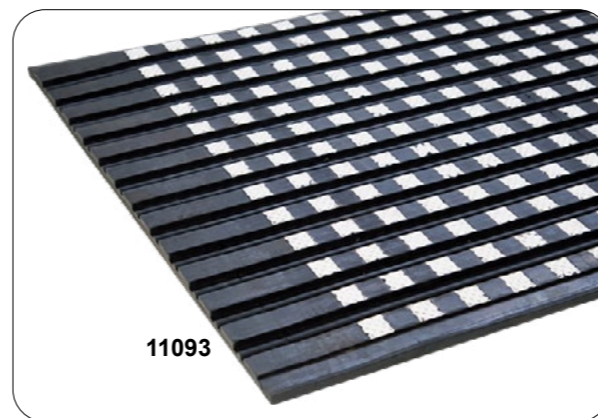

11093

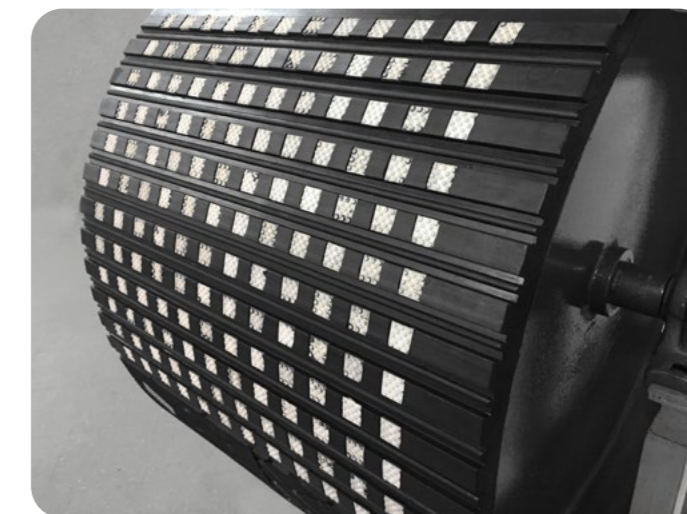

Mod. R	Code	Shape	Width	Depth	Box
	12409	R1	mm 3-4	7	20 pcs
	12410	R2	mm 5-6	8	20 pcs
	12411	R3	mm 6-8	10	20 pcs
	12412	R4	mm 9-10	14	20 pcs
	12413	R5	mm 10-14	16	20 pcs
	12419	R6	mm 16-22	16	10 pcs
Mod. W-C					
	12414	W1	mm 3-4	7	20 pcs
	12415	W2	mm 5-6	8	20 pcs
	12416	W3	mm 6-8	10	20 pcs
	12417	W4	mm 9-10	14	20 pcs
	12418	W5	mm 10-14	16	20 pcs
	12420	W6	mm 20-28	16	10 pcs
	12421	C7	mm 20-26	20	10 pcs
	12422	C8	mm 22-28	22	10 pcs
	12423	C9	mm 22-38	30	10 pcs



11012



11221



10586



12556



11107



12254



12256



12255

Code	Model
12254	Marcatore 300 W / Tire brander 300 W
12255	Resistenza per marcatore / Heater for tire brander
12256	Alfabeto completo / Complete alphabet
12257	Numeri / Numbers

Code	Model
11107	Primer VMR 700 gr / Primer VMR 700 gr
11093	Dutyflex rivestimento per tamburi gomma / Ceramica 2.595 X 495 x 15 mm Dutyflex pulley lagging rubber / Ceramic 2.595 X 495 x 15 mm
11012	Martello pneumatico per tamburi / Pneumatic hammer for lagging
10586	Martello pneumatico con tampone in gomma dura / Pneumatic hammer with hard tip
12556	Martello in gomma Ø 50 mm - gr 500 / Rubber hammer Ø 50 - gr 500
11221	Martello calderario - gr 500 / Ball pein hammer - gr 500

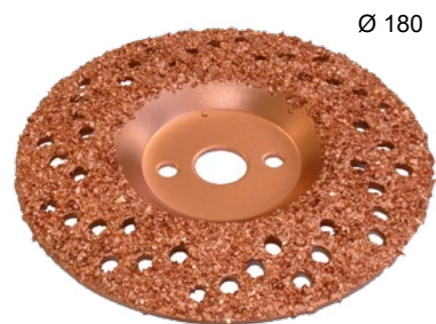

Ø 180

10937/10938

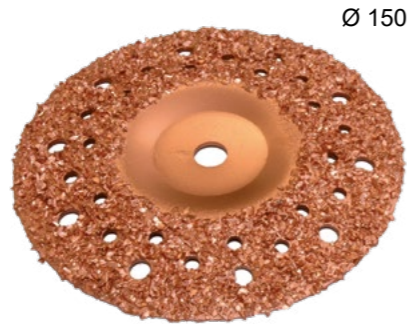

Ø 150

10935/10936

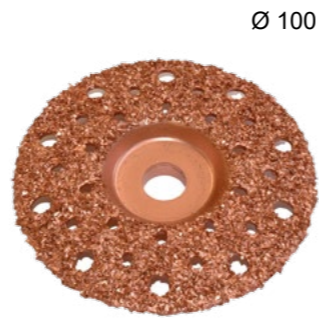

Ø 100

10931/10932

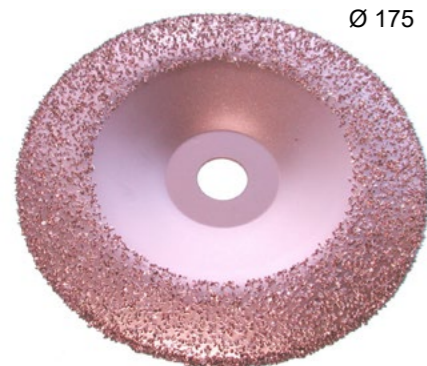

Ø 175

10939/10940



Ø 125

10933/10934



Ø 100

10138/10139



Ø 75

10136/10137



Code	Size	Hole	Grit
10931	100 x 2	16	18
10932	100 x 2	16	36
10933	125 x 2	22	16
10934	125 x 2	22	36
10935	150 x 2	13	18
10936	150 x 2	13	36
10937	180 x 2	22	18
10938	180 x 2	22	36
10939	175 x 2	22	16
10940	175 x 2	22	36
10136	Ø 75 x 25	3/8"	16
10137	Ø 75 x 25	3/8"	36
10138	Ø 100 x 40	3/8"	16
10139	Ø 100 x 40	3/8"	36

MOLE A STELLA/ STAR WHEELS

Code	Size	Hole	Grit
11233	Ø 150 x 6	60	16
11233-2	Ø 150 x 6	60	23
11234	Ø 150 x 6	60	36
11235	Ø 225 x 6	150	16
11236	Ø 225 x 6	150	36
11326	Ø 120 x 6	22	36
11328	Ø 100 x 6	19	23
11330	Ø 200 x 6	125	16

* Altre misure disponibili su richiesta
Other sizes available on request



Ø 170

10941

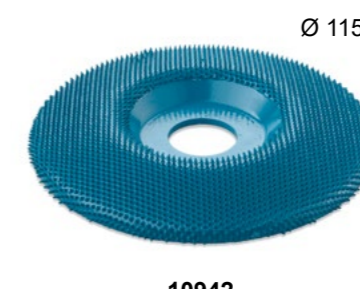

Ø 115

10942

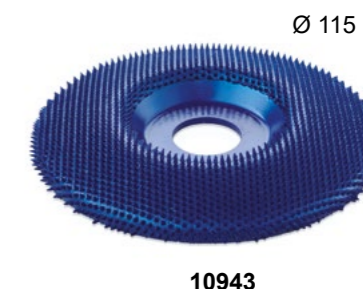

Ø 115

10943

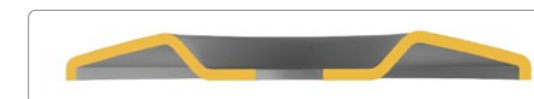

Ø 115

11227

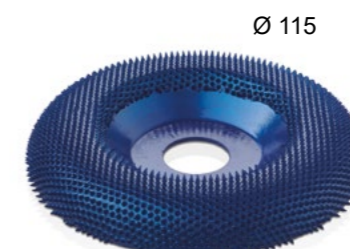

Ø 115

11228



Code	MCM	Size	Hole
10941	120 and 90	Ø 170mm	Ø 22
10942	70	Ø 115mm	Ø 22
10943	90	Ø 115mm	Ø 22
11227	70	Ø 115mm	Ø 22
11228	90	Ø 115mm	Ø 22



10945



Code	Model	Buffing width	Variable RPM	Carbides star wheels
10945	Smerigliatrice portatile per mole a stella Portable star wheel grinder	120 mm	1750	n°5 / Ø 120 x 6





Code	Model
11333	Sistema di spellatura cavi in acciaio d.4.9 / 13.2 mm / Cable stripping system d.4.9/13.2 mm
11337	Lame superiori 4,9 mm box 5 pcs / Blades top 4,9 mm box 5 pcs
11338	Lame inferiore 4,9 mm box 5 pcs / Blades bottom 4,9 mm box 5 pcs
11339	Lame superiori 5,6 mm box 5 pcs / Blades 5,6 mm 5 pcs
11340	Lame inferiori 5,6 mm box 5 pcs / Blades bottom 5,6 mm box 5 pcs
11341	Lame superiori 6,2 mm box 5 pcs / Blades top 6,2 mm 5 pcs
11342	Lame inferiori 6,2 mm box 5 pcs / Blades bottom 6,2 mm box 5 pcs
11343	Lame superiori 7,2 mm box 5 pcs / Blades 7,2 mm 5 pcs
11344	Lame inferiori 7,2 mm box 5 pcs / Blades bottom 7,2 mm box 5 pcs
11345	Lame superiori 7,5 mm box 5 pcs / Blades top 7,5 mm 5 pcs
11346	Lame inferiori 7,5 mm box 5 pcs / Blades bottom 7,5 mm box 5 pcs
11347	Lame superiori 8,1 mm box 5 pcs / Blades top 8,1 mm 5 pcs
11348	Lame inferiori 8,1 mm box 5 pcs / Blades bottom 8,1 mm box 5 pcs
11349	Lame superiori 8,6 mm box 5 pcs / Blades top 8,6 mm 5 pcs
11350	Lame inferiori 8,6 mm box 5 pcs / Blades bottom 8,6 mm box 5 pcs
11351	Lame superiori 8,9 mm box 5 pcs / Blades top 8,9 mm 5 pcs
11352	Lame inferiori 8,9 mm box 5 pcs / Blades bottom 8,9 mm box 5 pcs
11353	Lame superiori 9,7 mm box 5 pcs / Blades top 9,7 mm 5 pcs
11354	Lame superiori 9,7 mm box 5 pcs / Blades top 9,7 mm 5 pcs
11355	Lame superiori 10,6 mm box 5 pcs / Blades top 10,6 mm 5 pcs
11356	Lame inferiori 10,6 mm box 5 pcs / Blades bottom 10,6 mm box 5 pcs
11357	Lame superiori 11,3 mm box 5 pcs / Blades top 11,3 mm 5 pcs
11358	Lame inferiori 11,3 mm box 5 pcs / Blades bottom 11,3 mm box 5 pcs
11359	Lame superiori 12 mm box 5 pcs / Blades top 12 mm 5 pcs
11360	Lame inferiori 12 mm box 5 pcs / Blades bottom 12 mm box 5 pcs
11361	Lame superiori 12,5/13,2 mm box 5 pcs / Blades top 12,5/13,2 mm 5 pcs
11362	Lame inferiori 12,5/13,2 mm box 5 pcs / Blades bottom 12,5/13,2 mm box 5 pcs

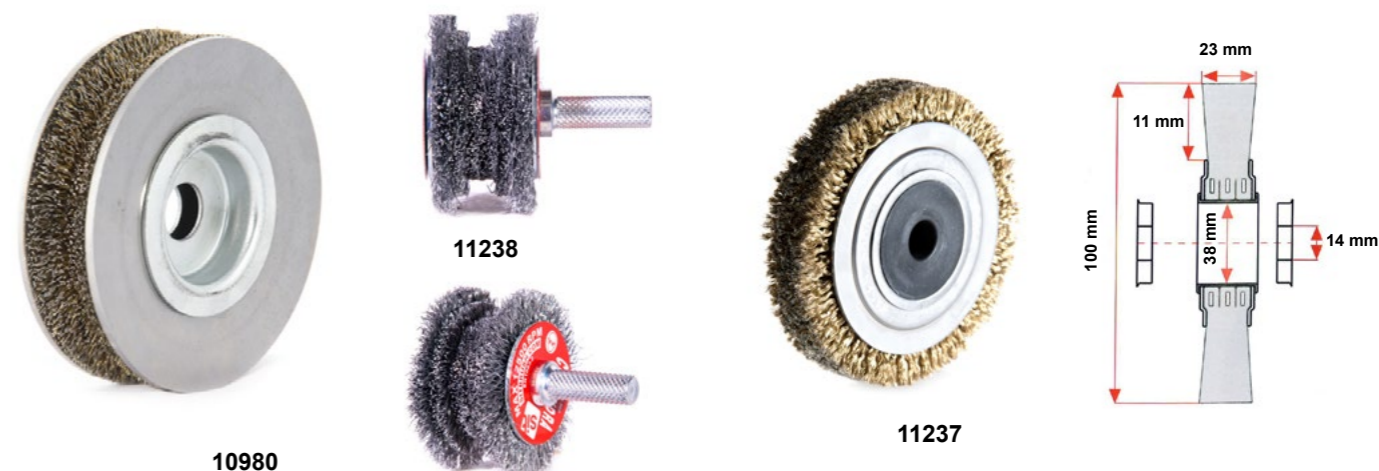

Code	Model	Hole/Stem
11033	Tagliabulloni L=600 mm / Bolt cutter L=600 mm	-
11034	Lama ricambio per tagliabulloni 11033 / Spare blade for bolt cutter 11033	-
11035	Tagliafuni in acciaio L= 600 mm / Wire cord cutter L=600 mm	-
10980	Spazzola circolare concava ø 100 x 27mm / Grooved wire brush ø 100 x 27 mm	Ø 16
11237	Spazzola circolare Ø 100 x 23 mm / Steel wire brush Ø 100 x 23 mm	Ø 38/14
11238	Spazzola circolare clepsydra ø 60 x 30 mm / Clepsydra steel wire brush ø 60 x 30 mm	Ø 10



11557

11558

11559



11560



11582

Code	Size	Model
11557	Ø 52 x 18	Pin 1,5 x 12
11558	Ø 52 x 27	Pin 1,5 x 12
11559	Ø 52 x 46	Pin 1,5 x 12
11560	Ø 52 x 76	Pin 1,5 x 12
11582	Ø 1,5 x 12	3.000 pcs/box
11604	Ø 1,5 x 12	9.000 pcs/box



11562



11565



11564



11563



11561



11566



11571

11572

11573



11570

Code	Smooth/Liscio
11570	40 x 10 mm
11571	40 x 12 mm
11572	40 x 18 mm
11573	40 x 46 mm



11567



11568

Code	Knurled/Zigrinato
11561	40 x 2,5 mm
11562	50 x 4 mm
11563	38 x 3 mm
11564	38 x 7 mm
11565	25 x 2 mm
11566	40 x 10 mm
11567	40 x 18 mm
11568	40 x 46 mm
11569	40 x 76 mm



11569

FINITURA - FINISHING



Code	Model	Size	Thickness
11060	VFBC-50	50x10.000 mm	1,40mm
11061	VFBC-70	70x10.000 mm	1,40mm
11062	VFBC-220	220x320 mm	1,40mm
11063	VFBC-300	300x500 mm	1,40mm
11064	VFBC-400	400x700 mm	1,40mm
11065	VFBC-50	50x1.100 mm	1,40mm
11066	VFBC-70	70x1.100 mm	1,40mm
11067	VFBC-100	100x1.100 mm	1,40mm
11068	VFBC-150	150x1.100 mm	1,40mm
11069	VFBC-100	100x10.000 mm	1,40mm
11070	VFBC-150	150x10.000 mm	1,40mm
11071	VFBC-220	220x10.000 mm	1,40mm
11072	VFBC-300	300x10.000 mm	1,40mm
11073	VFBC-500	500x10.000 mm	1,40mm
11087	Round patch VFBC-55 (20 pcs/box)	Ø 55 mm	-
11088	Round patch VFBC-115 (20 pcs/box)	Ø 115 mm	-
11089	Diamond patch VFBC-1-R (5 pcs/box)	160x130 mm	-
11090	Diamond patch VFBC-2-R (5 pcs/box)	260x200 mm	-
11091	Diamond patch VFBC-3-R (5 pcs/box)	360x270 mm	-

RINFORZATE - REINFORCED



11092

Code	Model	Size	Thickness
11074	VFBC-50	50x1.100 mm	4,15 mm
11075	VFBC-70	70x1.100 mm	3,75 mm
11076	VFBC-100	100x1.100 mm	3,75 mm
11077	VFBC-150	150x1.100 mm	4,75 mm
11078	VFBC-200	220x320 mm	4,75 mm
11079	VFBC-300	300x500 mm	4,75 mm
11080	VFBC-300	300x600 mm	4,75 mm
11081	VFBC-400	400x700 mm	4,75 mm
11082	VFBC-1000	100x10.000 mm	3,75 mm
11083	VFBC-1500	150x10.000 mm	4,75 mm
11084	VFBC-2200	220x10.000 mm	4,75 mm
11085	VFBC-3000	300x10.000 mm	4,75 mm
11086	VFBC-5000	500x10.000 mm	4,75 mm
11092	Reinforced diamond patch VFBC-3 R (5 pcs/box)	360x270 mm	-



10955



10952



10953



11240



11242



11243



11754



11753



11104

11105



11110

11105



11108 - 11109



12612



12613

Code	Model
11753	Trafilatore in gomma per riempimento crateri Ø 10 mm - 5 Kg / Hole filler strip Ø 10 mm - 5 Kg
11754	Gomma per la pulizia dell'estrusore 3x18x300mm / Cleaning rubber for extruders 3x18x300 mm - 1 box/5 rolls
10952	Trafilatore in gomma autovulcanizzante A+B 3x 20 x 5.500 mm / Self-curing A+B rubber 3x20 x 5.500 mm 2+2 Kg
10953	Kit soluzione mastice per A+B (1Kg+1Kg) / Glue solution kit for A+B compound (1Kg+1Kg)
10955	Gomma autovulcanizzante A+B (1Kg+1 Kg) / A+B Two parts self-curing rubber (1Kg+1Kg)
11108	Resina per riparazione a freddo eli-flex 150g / Resin for cold repair eli-flex 150g
11109	Resina per riparazione a freddo eli-flex 300g / Resin for cold repair eli-flex 300g

Code	Model
11104	Mastice VMR 660 gr. (SC4000) / VMR Cement 660gr. (SC4000)
11105	Indurente VMR per codice 11104 - 33gr / VMR Hardner for code 11104 - 33gr
11106	Kit VMR (SC4000) mastice 660 gr indurente 33gr / VMR Kit (SC4000) cement 660 gr + hardner 33gr
11110	Mastice poliuretano VMR (PVC) 660 gr / VMR PVC cement 660gr.
11111	Kit mastice poliuritanico VMR (PVC) 660 gr indurente 33gr / VMR Kit PVC cement 660 gr + hardner 33 gr
12612	Contenitore per colle / Glue box
12613	Spazzola e coperchio per contenitore 12612 / Spare lid and brush for 12612
11240	Pistola Permaflex / Permaflex dispensing gun
11241	Cartuccia doppia Permaflex 200x200 ml / Permaflex dual cartridge 200x200 ml
11242	Beccuccio miscelatore Permaflex / Permaflex mixing tip
11243	Primer speciale 125ml / Special primer 125ml



Questa macchina può essere usata con diversi tipi di nastro (gomma, PVC e PU) e viene prodotta seguendo le specifiche esigenze del cliente. Include sgorbie (fustelle) di diversi diametri per variare la tipologia del foro.

This machine is suitable for different types of conveyor belts (rubber, PVC and PU), and it is manufactured following the specific needs of each customer. It includes belt punches with different diameters for different type of holes.

Potenza / Power	1500 W
Potenza Elettrica / Electric Power	380 V
Peso / Weight	1000 Kg
Pressione / Air pressure	3-5 bar
Precisione / Accuracy	0.01 mm

mato

MODEL EC62G Up to 200 kN/m, Min pulley Ø 50 Belt Thickness 1.5-3.2 mm	MODEL EC125G Up to 315 kN/m, Min pulley Ø 75 Belt Thickness 3.2-4.8 mm	MODEL EC187G Up to 400 kN/m, Min pulley Ø 100 Belt Thickness 4.8-6.4 mm	Larghezza Nastro Belt Width
-	EC125G-100NC	EC187G-100NC	100 mm
-	EC125G-250NC	-	250 mm
EC62G-300NC	EC125G-300NC	EC187G-300NC	300 mm
-	EC125G-350NC	-	350 mm
EC62G-400NC	EC125G-400NC	EC187G-400NC	400 mm
EC62G-450NC	EC125G-450NC	EC187G-450NC	450 mm
EC62G-500NC	EC125G-500NC	EC187G-500NC	500 mm
EC62G-600NC	EC125G-600NC	EC187G-600NC	600 mm
EC62G-750NC	EC125G-750NC	EC187G-750NC	750 mm
EC62G-800NC	EC125G-800NC	EC187G-800NC	800 mm
EC62G-900NC	EC125G-900NC	EC187G-900NC	900 mm
EC62G-1000NC	EC125G-1000NC	EC187G-1000NC	1000 mm
EC62G-1050NC	EC125G-1050NC	EC187G-1050NC	1050 mm
EC62G-1200NC	EC125G-1200NC	EC187G-1200NC	1200 mm
EC62G-1500NC	EC125G-1500NC	EC187G-1500NC	1500 mm

Giunzioni in acciaio zincato, disponibili anche in inox. Il box contiene 4 set di giunzioni (8 strisce + 4 cavi + 10 rondelle). I cavi sono in acciaio flessibile ricoperto in Nylon, ma sono disponibili anche con una chiusura in acciaio rigido.

Galvanized steel fasteners, available also in stainless steel. The box contains 4 set of lacing (8 strips + 4 connecting pins + 10 washers). The connecting pins are made of flexible steel and nylon covered. They are also available in steel spring wire.



Splicing Kit EFEK-G



Strumento di installazione EasyFix EFT
Installation Tool EasyFix EFT

Code	Model	Size
111144	EasyFix EFT-100/4"	100 mm
111145	EasyFix EFT-300/12"	300 mm
111146	EasyFix EFT-600/24"	600 mm
111147	EasyFix EFT-1200/48"	1200 mm

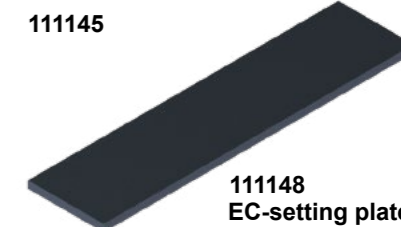
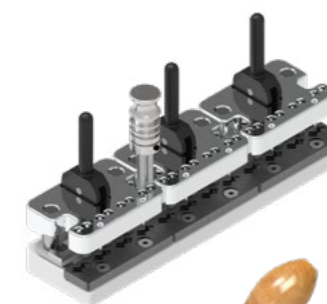

111149
Supergrip-Skiver

Model U24BS Belt Thickness 5.0-6.0 mm	Model U24CS Belt Thickness 6.0-7.0 mm	Model U24AS Belt Thickness 4.0-5.0 mm	Model H24BS Belt Thickness 5.0-6.0 mm	Up to 520 kN/m Min pulley Ø 75
Belt width mm	Belt width mm	Belt width mm	Belt width mm	Packing units
100-110	100-110	-	100-110	12
111-121	111-121	-	111-121	12
120-130**	-	-	-	12
122-132	122-132	-	122-132	12
133-143	133-143	-	133-143	12
144-154	144-154	-	144-154	12
155-165*	155-165	155-165	155-165	12
166-176*	166-176	-	166-176	12
177-187*	177-187	-	177-187*	12
188-198*	188-198*	188-198*	188-198*	12
199-209	199-209	-	199-209	10
210-220*	210-220*	-	210-220*	10
221-231*	221-231*	221-231*	221-231*	10
232-242	232-242	-	232-242	10
232-250**	-	-	-	8
243-253	243-253	-	243-253	8
254-264	254-264	-	254-264	8
265-275	265-275	-	265-275	8
276-286*	276-286*	-	276-286*	8
287-297	287-297	-	287-297	8
298-308*	298-308	-	298-308*	8
309-319	309-319	-	309-319	8
320-330	320-330	-	320-330	8
331-341	331-341	-	331-341	8
342-352	342-352	-	342-352	8
353-363	353-363	353-363	353-363*	8 (6 H24*)
364-374*	364-374	-	364-374	8
375-385*	375-385	-	375-385	8



H24



U24



Tutte le confezioni contengono i cavi se non diversamente indicato: * disponibile senza cavi / ** disponibile solo senza cavi.
Per richieste usare il codice del modello e la larghezza del nastro: "U24BS 100-110, U24CS 243-253, H24BS 342-352.."

All packing units include connecting pins whereas otherwise indicated: *available without connecting pins / ** available only without connecting pins.

To inquire please use the model code and the belt width : "U24BS 100-110, U24CS 243-253, H24BS 342-352.."

U24 model

Installato con martello su piano di lavoro (morsa) / Hammer installed fasteners used on a Bench Vice

Code	Model	Width
111150	Profi 5-55	55 mm
111151	Profi 19-209	209 mm
111152*	Profi 25-275	275 mm

* Disponibile in kit che include il raschiatore 111170 con profondità regolabile, il martello pneumatico 111171 e una valigetta

**Comes also in a kit including the belt skiver 111170 with adjustable skiving depth, the pneumatic hammer 111171 and a tool box



111151

H24 model

Installato con martello (senza morsa) / Hammer installed fastener without Bench Vice

Code	Model	Width
111153**	Profi 15-180	180 mm
111154**	Profi 15-350	350 mm
111155	Profi 15-500	500 mm
111156	Profi 30-1000	1000 mm

**Disponibile in kit che include il raschiatore 111164, un martello da 300g e una valigetta

**Comes also in a kit including a belt skiver 111164, a 300g hammer and a tool box



111153



mato



111157 / 111158
H24 Belt lacing set



111159
BARETOOL 5-55

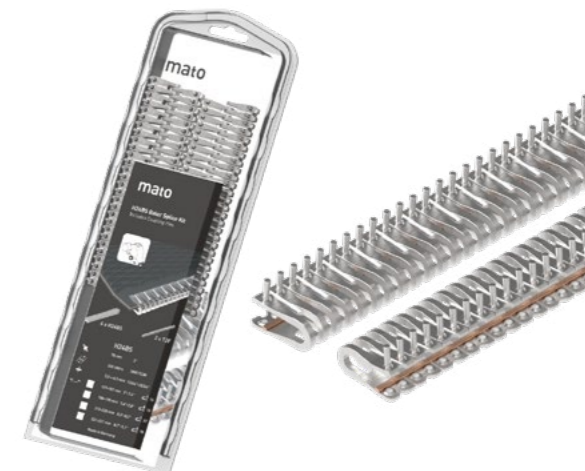

H24 BS Eco-belt lacing set

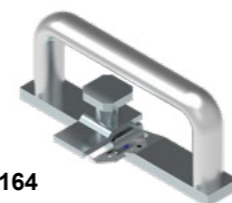

111164
Belt Skiver 18
Skiving width 18mm



111170
Belt Skiver 18 Pro
Skiving width 18mm
Adjustable depth



111171
Pneumatic Hammer Profi

GIUNZIONI AVVITABILI / BOLT PLATE FASTENERS

Le giunzioni Bolt Plate sono usate per giuntare nastri e riparare strappi
The Bolt Plate screw system is used for belt splicing and rip repairs



Code	Model	Belt width	Belt thickness	Min pulley Ø	kN/m
111172	MS140-25 pcs/box	750 mm	5-11 mm	250 mm	400
111173	MS190-25 pcs/box	750 mm	8-14 mm	400 mm	630
111174	MS140-100 pcs/bucket	3000 mm	5-11 mm	250 mm	400
111175	MS190-100 pcs/bucket	3000 mm	8-14 mm	400 mm	630



111176
Belt Punch



111177
Power Punch



10516
Quick Change Chuck



111178
Hand Nut Tightener



111179
Power Nut Tightener



111180
Bolt Breaker

Model	Belt Strength	Min pulley Ø	Belt Thickness	Belt Width
H35AE	Up to 1050 kN/m	250 mm	6-9 mm	Up to 650 mm
H35BE	Up to 1050 kN/m	250 mm	7-11 mm	Up to 800 mm Up to 900 mm
H37AE	Up to 1400 kN/m	350 mm	8-12 mm	Up to 1000 mm
H37BE	Up to 1400 kN/m	350 mm	10-14 mm	Up to 1050 mm Up to 1200 mm
H67CE	Up to 1800 kN/m	500 mm	12-16 mm	Up to 1350 mm
H67DE	Up to 1800 kN/m	500 mm	15-18 mm	Up to 1400 mm Up to 1600 mm

mato



Le giunzioni sono disponibili anche in acciaio inox. / The fasteners are also available in stainless steel.
I cavi devono essere ordinati separatamente. / The connecting pins need to be ordered separately.

Installation unit HTA H30 for H35 and H37 fasteners	Installation unit HTA H60 for H67 fasteners	Size
111181	111186	400 mm
111182	111187	1000 mm
111183	111188	1200 mm
111184	111189	1400 mm
111185	111190	1600 mm

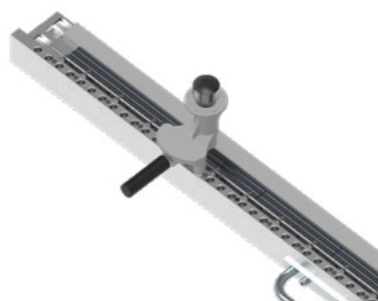

11118 Belt skiver 17/20



Lenght	Connecting Pins
635 mm	P1S/P1E- P2S/P2E
735 mm	P1S/P1E - P2S/P2E - P3E
785 mm	P1S/P1E - P2S/P2E - P3S/P3E - P4S/P4E - P5E
885 mm	P1S/P1E - P2S/P2E - P3S/P3E - P4S/P4E - P5E
985 mm	P1S/P1E - P2S/P2E - P3S/P3E - P4S/P4E - P5E
1035 mm	P1S/P1E - P2S/P2E - P3S/P3E - P4S/P4E - P5E
1185 mm	P1S/P1E - P2S/P2E - P3S/P3E - P4S/P4E - P5E
1335 mm	P1S/P1E - P2S/P2E - P3S/P3E - P4S/P4E - P5E
1385 mm	P1S/P1E - P2S/P2E - P3S/P3E - P4S/P4E - P5E
1585 mm	P1S/P1E - P2S/P2E - P3S/P3E - P4S/P4E - P5E
1785 mm	P2S - P3S - P4S
1985 mm	P4S/P4E - P5E

Connecting Pins	Fastener model	Min Ø	Belt Thickness	kN/m
P1S/P1E	H35AE - H35BE	5.3 mm	5-7 mm	1050
P2S/P2E	H35AE - H35BE H37AE - H37BE	6.4 mm	8-11 mm	1400
P3S/P3E	H37AE - H37BE	7.1 mm	11-16 mm	1400
P4S/P4E	H67CE - H37DE	8.5 mm	12-18 mm	4000
P5E	H67DE	10.5 mm	17-18 mm	1800

I cavi S sono fatti di acciaio inox cromato. / I cavi E sono fatti in acciaio speciale.
The S connecting Pins are made of Stainless Chromium Steel. / The E connecting Pins are made of Special Steel.



11115 Pneumatic Hammer 6 bar max



11114 Hammer HM (2 kg)



11116/11117 Lacing head HK



11119 Hacksaw

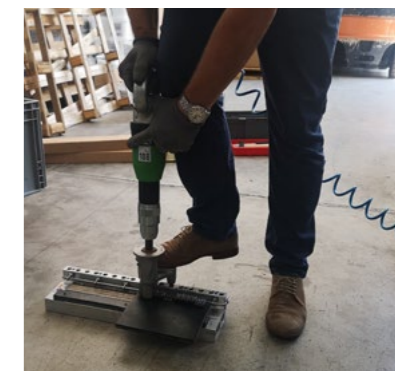

Code	Model
11224	Ginocchiere semi-rigide / Knee pads - semi rigid shell
12618	Guanti da lavoro / Work gloves
12660	Guanti con dorso in crosta / Gloves with reinforced palms
12619	Cuffia anti-rumore / Ear-muffs
12661	Inserti auricolari con archetto / Earplugs
12620	Occhiali in policarbonato / Polycarbonate eyeglass



12661



11224



12619



12620



12660



12618

SISTEMA TRDD / TRDD SYSTEM



- Per pneumatici AUTOCARRO da 8.25 fino a 12.00×24 e per pneumatici AGRICOLI da 9.5-32 fino a 12.4-38
- Disponibili anche il sistema di riparazione fianchi (SRS) e il sistema di riparazione talloni (BRS)
- Consigliato per postazioni fisse il sistema TRM copre tutte le misure autocarro e agricolo fino a pneumatici OTR di piccole dimensioni

- For TRUCK tire sizes from 8.25 to 12.00×24 and for AGRI tire sizes from 9.5-32 to 12.4-38
- Available the sidewall system (SRS) and the bead repair system (BRS)
- Suggested for fixed positions, the TRM system covers all the truck and agri sizes up to small OTR tires

Code	Model
TRRS D	Pannello di controllo / Control panel
TRR2213H (220V)	Resistenza interna (tessili) / Inner heat pad (Bias)
TRR2210H (220V)	Resistenza interna (radiali) / Inner heat pad (Radial)
TR911/13W	Cylinder air bag (cuscino)
TR1315/15W	Cylinder air bag (super single)
TRR2213H (220V)	Resistenza esterna / Outside heat pad
TRR2213E (4 Strap)	Cuscino piatto / Flat bag
TROC4	Cinghie / Straps

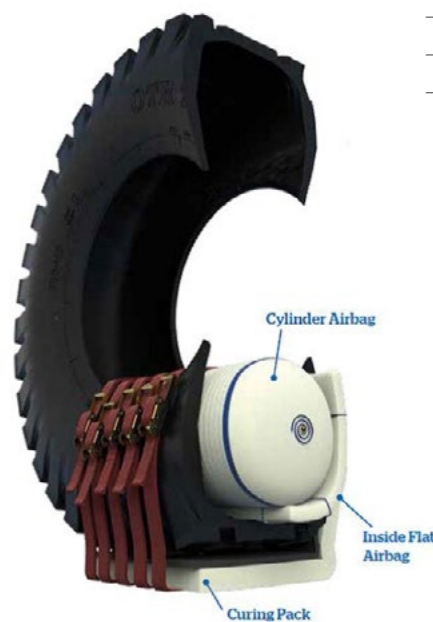

TRDD Application Chart

TRACTOR/ SECTION WIDTH	TRUCK TYRE SECTION WIDTH	CYLINDER BAG	INSIDE HEAT PAD		OUTSIDE HEAT PAD	OUTSIDE AIRBAG EXTERNAL PACK WITH FLAT BAG & STRAPS
			BIAS	RADIAL		
9.5 TO 12.4 INCHES	8.25 TO 12.00"	TR911/13W	TRR2213H	TRR2210H	TRR2213H	TRR2213E TROC 4
260/70R TO 320/85R MM	235 TO 295 MM	TR1212W	TRR2213H	TRR2210H	TRR2213H	TRR2213E TROC 4
SUPER SINGLE/ WIDE BASE	365/80-22.5 TO 445/65-22.5	TR1315/15W	TRR2213H	TRR2210H	TRR2213H	TRR2213E TROC 4
THE TRDD SYSTEM CAN BE EXTENDED UPWARDS TO COVER OTR TYRES UP TO 21.00 SECTION WIDTH						
OTR	13.00 TO 17.5" TYRE EXTENSION 330 TO 445 MM	TR1315/20W	MR2519H	MR3015H	MR2621H	TRR2621E TROC5XL
	18.00 TO 21.00" TYRE EXTENSION 455 TO 530 MM	M1721/24W	MR2519H	MR3015H	MR2621H	TRR621E TROC5XL



SISTEMA OTR OTR SYSTEM

- Per pneumatici OTR da 13.00 a 70/70-63
- Per pneumatici radiali e convenzionali (agricoli)
- Per fianchi, spalle e battistrada
- Pannello di controllo consigliato M100 (R-type)

- For OTR tire sizes from 13.00 to 70/70-63
- For radial and bias tires
- For sidewall, shoulder and crown
- Suggested control panel M100 (R-type)

Our Application Chart

WIDE BASE	TYRE SECTION (INCHES)	CYLINDER BAG	INSIDE FLAT BAG	INSIDE HEAT PAD		OUTSIDE HEAT PAD	EXTERNAL PACK WITH FLAT BAG & STRAPS
				BIAS	RADIAL		
14.4-24 TO 16.9-38	13.00 TO 17.5	TR1315/20W		MR2519H	MR3015H	TRR2621H	TRR2621E WITH TROC5XL STRAPS
18.4-34 TO 20.8-42	18.00 TO 21.00	M1721/24W		MR2519H OR MR2626H	MR3015H	TRR2621H	TRR2621E WITH TROC5XL STRAPS
23.1-26 TO 30.5-32	23.5 TO 26.5	M1721/24W	MR4824	MR2519H OR MR2626H	MR3015H	TRR2621H	TRR2621E WITH TROC5XL STRAPS
25/65-25	27.00 TO 29.5	M1721/24W	MR4824 MR5432*	MR2519H OR MR2626H	MR3015H OR MR4220H	TRR2621H	TRR2621E WITH TROC5XL STRAPS
35/65-33 TO 45/65-45	30.00 TO 37.5	M2732/32W	MR5432	MR3132H OR MR2626H	MR4220H OR MR4224H	MR2626H OR MR3132H	MR4832E WITH M45/6/7 (IHG) 6 STRAPS
49.5/85-57 TO 50/65-51	40.00	M3842/32W		MR3132H OR MR2626H	MR4220H OR MR4224H OR MR4824H OR MR5224H	MR2626H OR MR3132H	MR4832E WITH M45/6/7 (IHG) 6 STRAPS
46/90-57		M3842/32W	MR5432*		MR4220H OR MR4224H OR MR4824H OR MR5224H	MR2626H OR MR3132H	MR4832E WITH M45/6/7 (IHG) 6 STRAPS
50/80-57 TO 55/80-57		M4447/32W		MR3132H OR MR2626H	MR4224H OR MR4824H OR MR5224H	MR2626H OR MR3132H	MR4832E WITH M45/6/7 (IHG) 6 STRAPS
53.5/85-57 TO 55.5/85-63 TO 55.5/85-57 TO 55.5/85-63		M4447/32W	MR7532 OR MR9032	MR3132H OR MR2626H	MR4220H OR MR4224H OR MR4824H OR MR5224H	MR2626H OR MR3132H	MR4832E WITH M45/6/7 (IHG) 6 STRAPS
59/80-63 TO 60/80-57 TO 70/70-57		M5054/32W	MR9032	MR3132H OR MR2626H	MR4220H OR MR4224H OR MR4824H OR MR5224H	MR2626H OR MR3132H	MR4832E WITH M45/6/7 (IHG) 6 STRAPS

*When repairing 27.00" through 29.5" section widths in Bias tyres, it may be necessary to use a MR5432 to fully cover the patch. For certain brands of 46/90-57 tyres, it may be necessary to also use an MR5432 inside Flat Airbag to fully fill the section void.



info@vmrubber.com

+39 0464 1940003



Viale Giovanni Caproni 17/A
38068 Rovereto (Tn) Italy
www.vmrubber.com